

- HOSE LOAD
1. 200FT OF 3"
  2. 300FT OF 3"
  3. 1200FT OF 5"
  4. 250FT OF 2.5"
  5. 300FT OF 1 3/4"

Left Side Compartmentation				
Compt	Doors	Opening Dimensions	Inside Dimensions	Volume
WxHxD				
L1	Roll Up	23x49	30x59x24.25	24.8 CU FT
L2	Roll Up	53x18	60x28x24.25	32 CU FT
L3	Roll Up	43x49	50x59x24.25	41.4 CU FT
Right Side Compartmentation				
Compt	Doors	Opening Dimensions	Inside Dimensions	Volume
R1	Roll Up	23x35	30x45x24.25	18.9 CU FT
R3	Roll Up	43x35	50x45x24.25	31.6 CU FT
Rear Compartmentation				
Compt	Doors	Opening Dimensions	Inside Dimensions	Volume
A1	Roll Up	41x26	48x36x22.25	22.3 CU FT
				Total Volume
				171 CU FT

LADDER RACK  
24' 2 SEC  
14' ROOF  
10' FOLDING

HALE QMAX-1500 GPM SS  
750 GAL WATER  
HALE SMART FOAM 2.1  
20 GAL FOAM

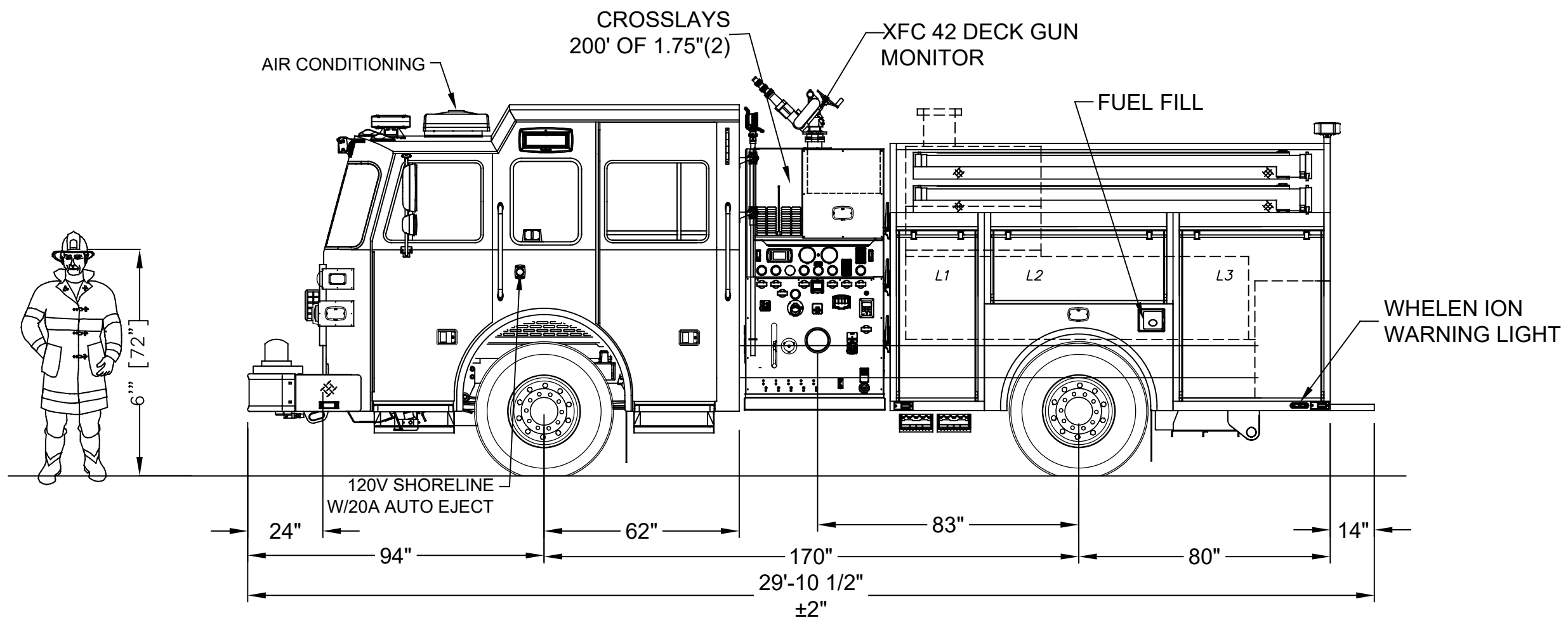
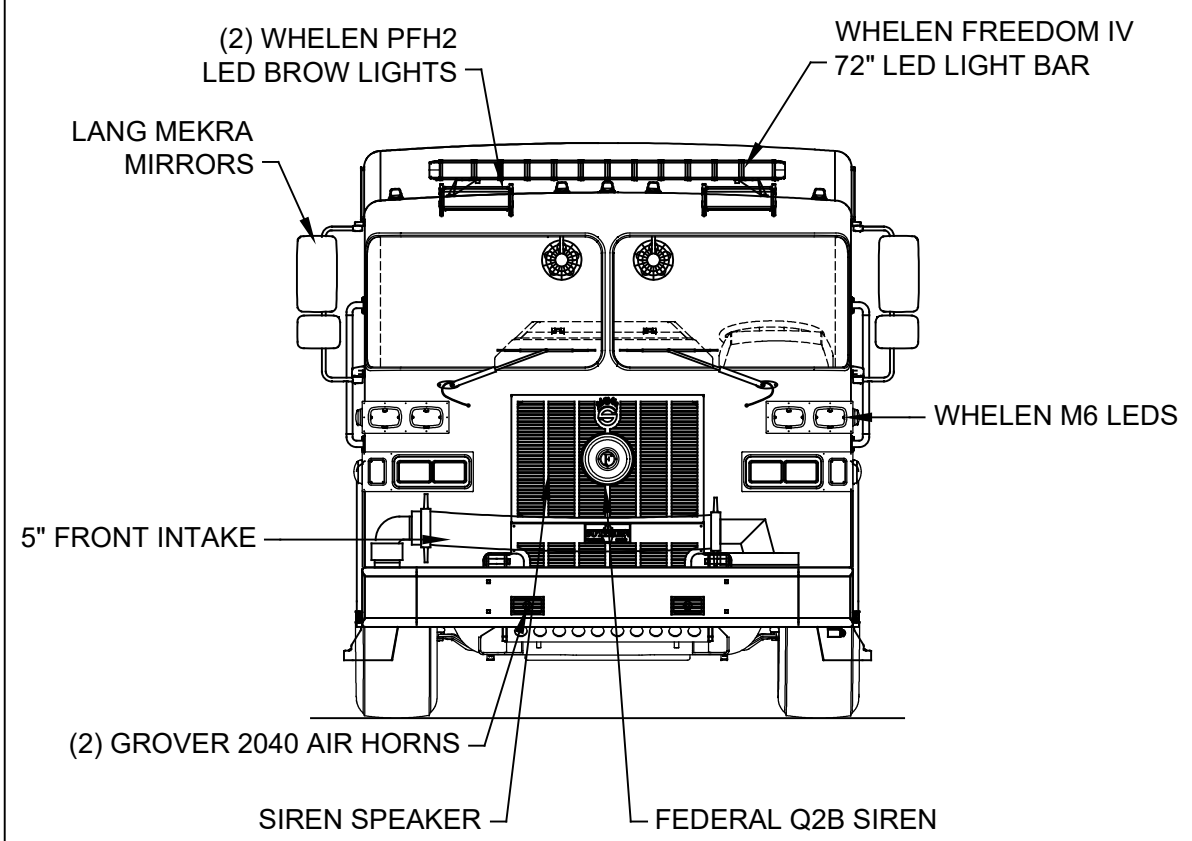

DIMENSIONS SHOWN ON THIS DRAWING ARE APPROXIMATE AND ARE SUBJECT TO MINOR DEVIATIONS DURING CONSTRUCTION.

IN THE EVENT OF A DISCREPANCY BETWEEN THE SUTPHEN SPECIFICATIONS AND DRAWING, THE SUTPHEN SPECIFICATIONS SHALL PREVAIL.

DRAWING IS FOR REFERENCE ONLY. SOME ITEMS PROPOSED MAY NOT BE SHOWN OR NOTED.

CUSTOMER APPROVAL

NAME: \_\_\_\_\_

TITLE: \_\_\_\_\_

DATE: \_\_\_\_\_

REV.	DESCRIPTION	BY	DATE

DRAWN BY:  
S. DORFMAN

DATE:  
8/31/22

MFG. FACILITY:  
SUTPHEN EAST LAKE ARIEL, PA

TOWN OF CLAYTON FIRE DISTRICT  
CLAYTON, NY

PROGRAM 2 PUMPER - S1-ST5

DWG. NO.: HS-7571